

Strengthen Posts and Beams

Prepared by the Peninsulas Emergency Preparedness Committee
of Washington 11/00 (www.pep-c.org)

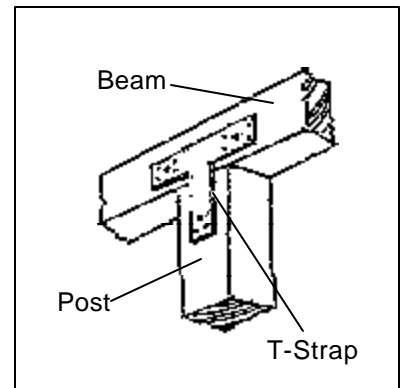

Provide post anchors at bottom of posts in crawl spaces rather than just resting on concrete pad (i.e., patio decks, stairs). Use metal connectors at post and beam connections in garages, decks, porches and basements.

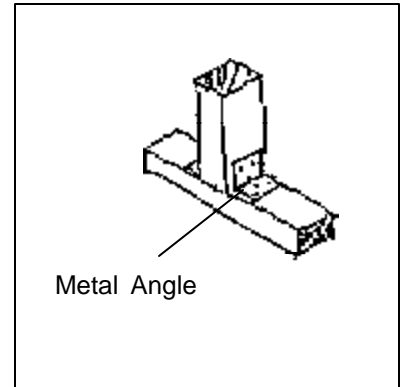
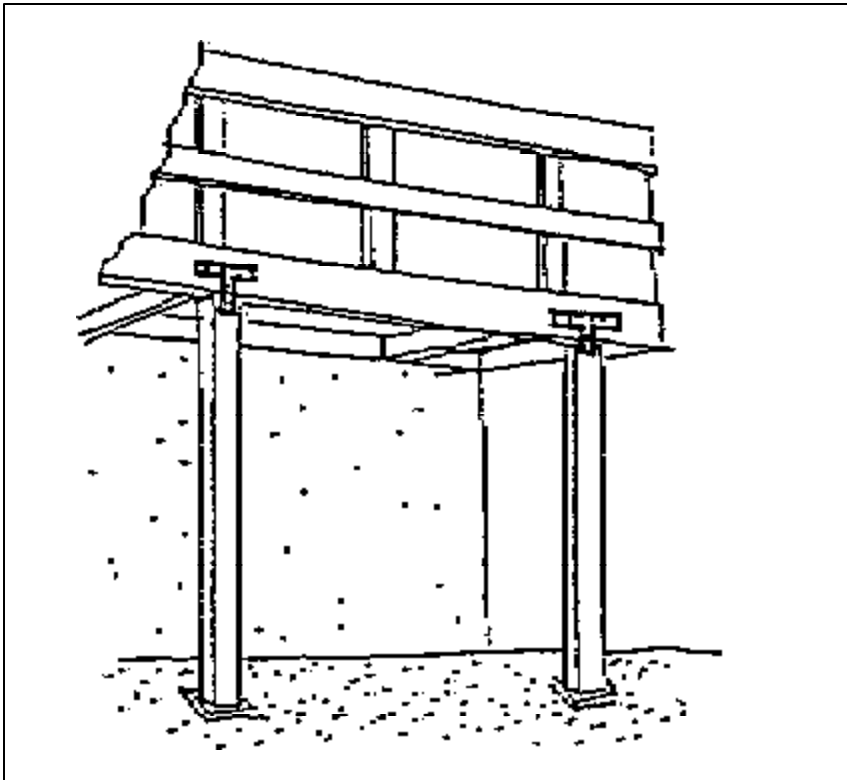